

Electric pumps for the supply of grease and for high pressure lubrication in dispensing lines if only electrical power is available.

This series allows the combination of 3 different motors with different suction tubes and different planetary reduction gears, thus offering a total of 16 combinations which permit suitable solutions for various requirements.

Grease



Art.no. 4090

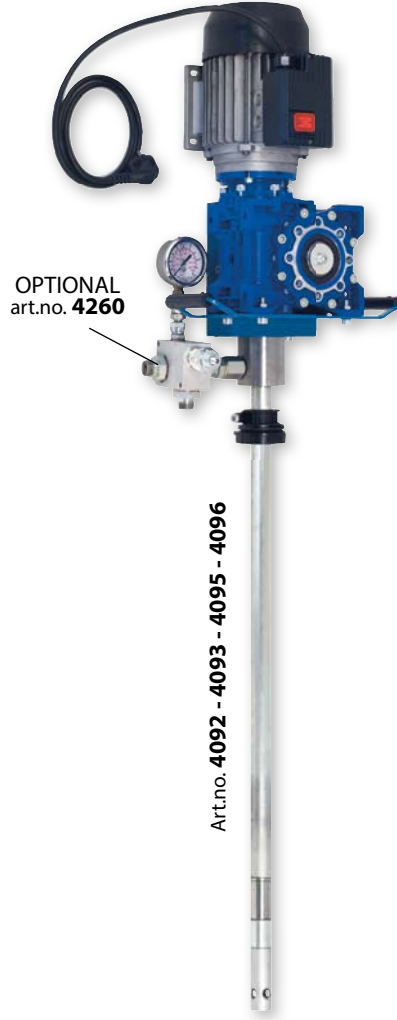

OPTIONAL
art.no. 4260

Art.no. 4092 - 4093 - 4095 - 4096



Art.no. 4097

new

Art. no.	Voltage	Reducers	Ø Suction tube	Max outlet pressure	Delivery	RPM	Power	Suitable for drums of	Weight
4090/20	12 VDC	20 : 1	28x14 mm	200 bar (2900 psi)	100 g/min	3400	250 W	18 - 25 kg	12 kg
4090/50								50 kg	13 kg
4090/180								180 kg	14 kg
4092/20	230 VAC - 50 Hz	7.5 : 1	28x14 mm	300 bar (4350 psi)	400 g/min	1400	750 W	18 - 25 kg	20 kg
4092/50								50 kg	21 kg
4092/180								180 kg	22 kg
4093/20			28x16 mm	100 bar (1450 psi)	1200 g/min			18 - 25 kg	20 kg
4093/50								50 kg	21 kg
4093/180								180 kg	22 kg
4095/20	400 VAC - 50 Hz	7.5 : 1	28x14 mm	400 bar (5800 psi)	400 g/min	1400	750 W	18 - 25 kg	22 kg
4095/50								50 kg	23 kg
4095/180								180 kg	24 kg
4096/20			28x16 mm	200 bar (2900 psi)	1200 g/min			18 - 25 kg	22 kg
4096/50								50 kg	23 kg
4096/180								180 kg	24 kg
4097/180	50x22 mm	10 bar (145 psi)	8000 g/min	180 kg	26 kg				

The a. m. performance values are based upon the following test conditions: lithium grease NLGI 0 at 22°C -- free flow outlet.